

STARCYL

AIR CYLINDERS

SPACE-SAVER



WWW.STARCYL.COM

- ✓ Bore size from 1½" to 10"
- ✓ Stroke up to 40"
- ✓ Save Space up to 35% based on 4" Bore, 1" Stroke
- ✓ 250 PSI AIR, OIL
- ✓ Two-Year Warranty
- ✓ Economic design

STAR2 SERIES

NFPA STYLE MOUNT

STAR2 SPACESAVER DESIGN FEATURES

- A Solid Aluminum Head & Cap**
Machined from solid aluminum bar stock (6061 T6) and black anodized for corrosion resistance. (Also available in Stainless Steel).
- B Piston**
Machined from solid aluminum bar stock (6061-T6) thicker than the standard pancake.
- C Hard Anodized ID Aluminum Tube**
(60 Rc) Provides superior wear resistance, and lower friction coefficient for maximum seal life. (Also available in Stainless Steel.)
- D Piston Seal**
Nitrile Quad X seal provides better sealing with air and oil. (temperature: -48 to 104°C or -54 to 219°F). (U cup also Available)
- E O-ring Tube End Seals**
Nitrile O-ring design is pressure compensating and reusable.

- F Rod Seal**
Quad X gives the best seal and wipes dirt out for less maintenance and longer life of the cylinder.
- G Piston Wear Ring**
Nylon material is designed for low friction, and to ensure maximum wear in the cylinder in side load application. Eliminates metal-to-metal contact.
- H Rod Bearing**
Oil impregnated sintered bronze minimizes operating friction in non-lube applications and provides maximum support of the piston rod.
- I Piston Rod**
High strength steel. NITROCARBURIZING for highly corrosion-resistant coating, reliable performance and long life rod seal. Less friction. (Also available in Stainless steel).
- J Tie rods**
Corrosion resistant, stress proof steel maintains uniform compression on tube end seals. (Stainless may be used)

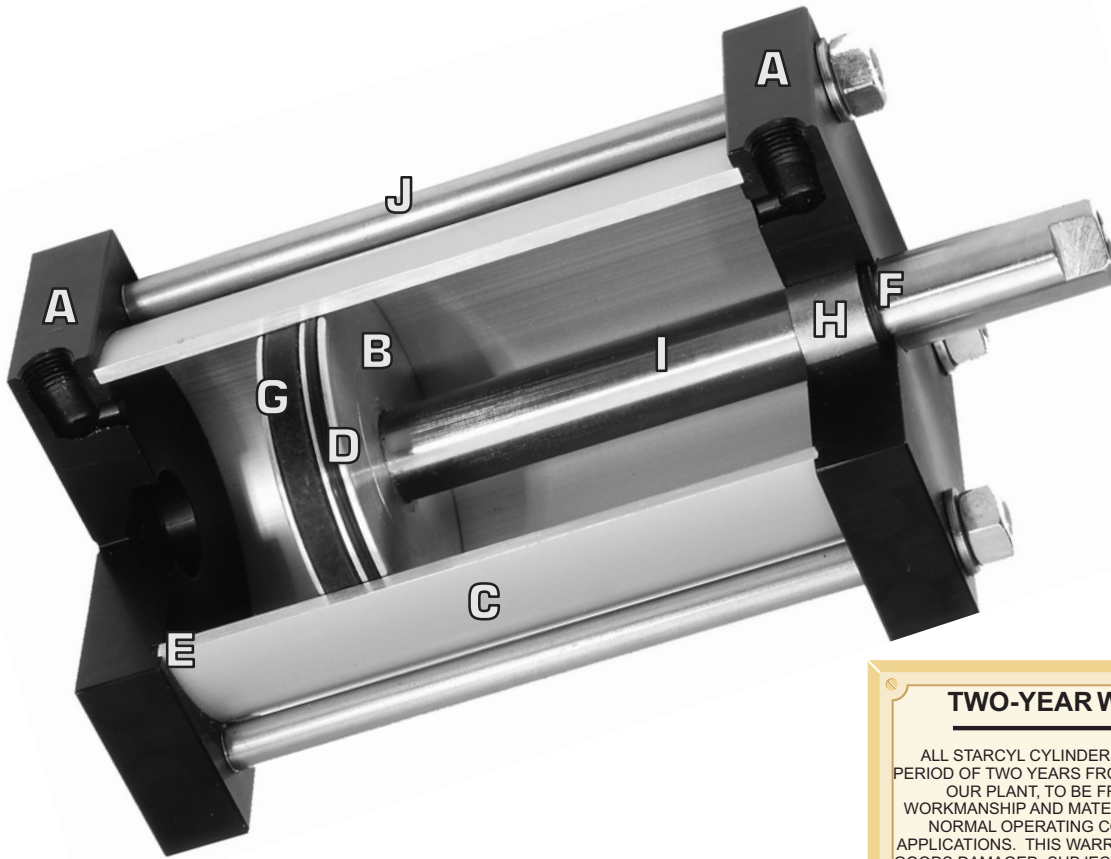

TWO-YEAR WARRANTY

ALL STARCYL CYLINDERS ARE WARRANTED FOR A PERIOD OF TWO YEARS FROM DATE OF SHIPMENT FROM OUR PLANT, TO BE FREE FROM DEFECTS IN WORKMANSHIP AND MATERIAL UNDER CORRECT USE, NORMAL OPERATING CONDITIONS AND PROPER APPLICATIONS. THIS WARRANTY DOES NOT EXTEND TO GOODS DAMAGED, SUBJECTED TO ACCIDENT, ABUSE OR MISUSE AFTER SHIPMENT FROM OUR FACTORY, NOR TO GOODS ALTERED OR REPAIRED BY ANYONE OTHER THAN AUTHORIZED STARCYL REPRESENTATIVES.

STARCYL CYLINDER INC.

PH : 1-877-STARCYL (782-7295)

INT'L: 1-888-332-1711

FAX (425) 920-0504

STAR2 SPACESAVER BASIC CYLINDER

ST2 BASIC MOUNT

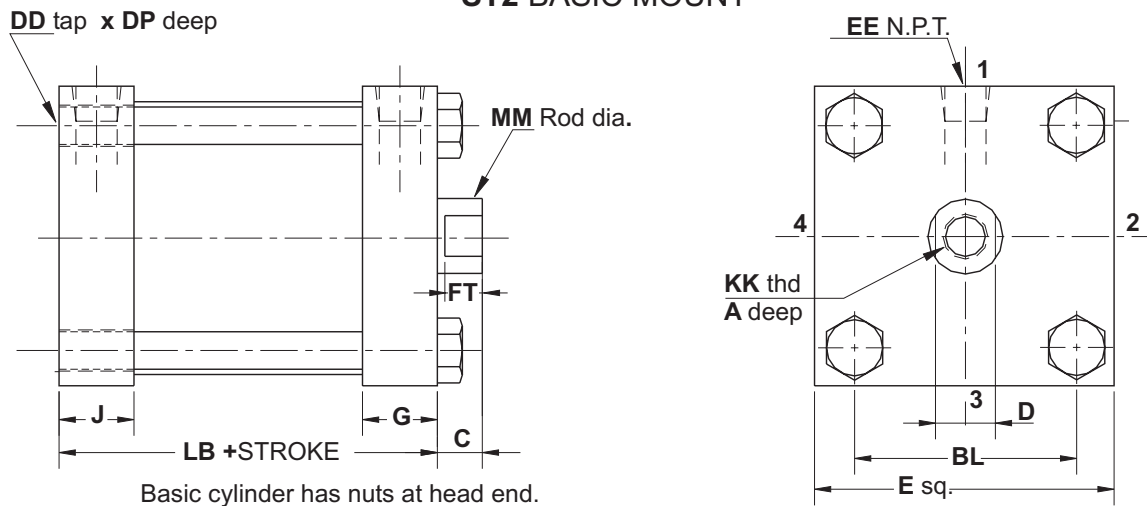

Basic cylinder has nuts at head end.
Option NC for nuts at cap end.

BORE	1 1/8	1 1/2	2	2 1/2	3 1/4	4	5
A	3/4	3/4	3/4	3/4	1 1/8	1 1/8	1 1/8
BL	1.19	1.43	1.84	2.19	2.78	3.32	4.12
C	3/8	3/8	3/8	3/8	1/2	1/2	1/2
D	3/8	1/2	1/2	1/2	7/8	7/8	7/8
DD	10-32	1/4-20	5/16-18	5/16-18	3/8-24	3/8-24	1/2-20
DP	5/16	5/16	5/16	5/16	7/16	7/16	7/16
E	1 1/2	2	2 1/2	3	3 3/4	4 1/2	5 1/2
EE	1/8	1/8	1/8	1/8	1/4	1/4	1/4
FT	1/4	5/16	5/16	5/16	7/16	7/16	7/16
G	5/8	5/8	5/8	5/8	31/32	31/32	31/32
J	5/8	5/8	5/8	5/8	31/32	31/32	31/32
KK	3/8-24	7/16-20	7/16-20	7/16-20	3/4-16	3/4-16	3/4-16
LB	1 3/4	1 3/4	1 3/4	1 3/4	2 11/16	2 11/16	2 11/16
LD	1 3/4	1 3/4	1 3/4	1 3/4	2 11/16	2 11/16	2 11/16
MM	1/2	5/8	5/8	5/8	1	1	1

ST2D Double rod end

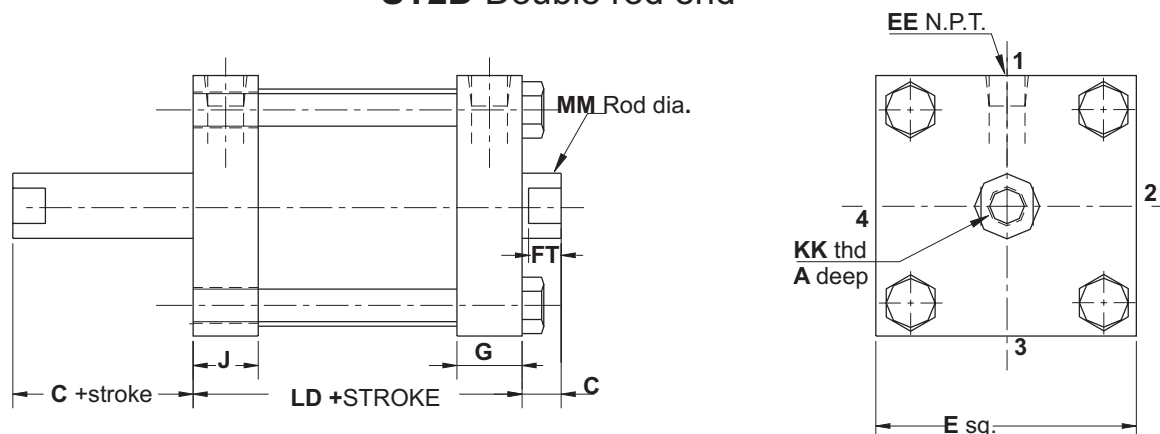

MOUNTING OPTIONS

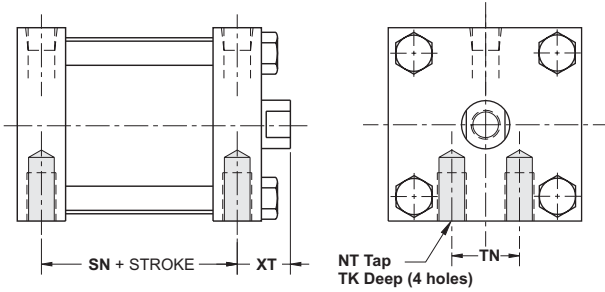

BORE	1 1/8	1 1/2	2	2 1/2	3 1/4	4	5
NT	#10-24	1/4-20	5/16-18	3/8-16	1/2-13	1/2-13	5/8-11
SN	1 7/8	1 7/8	1 7/8	1 7/8	1 23/32	1 23/32	1 23/32
TK	1/4	3/8	1/2	5/8	3/4	3/4	1
TN	1/2	5/8	7/8	1 1/4	1 1/2	2 1/16	2 11/16
XT	11/16	11/16	11/16	11/16	51/64	51/64	51/64

ST2S4 Bottom tap mount

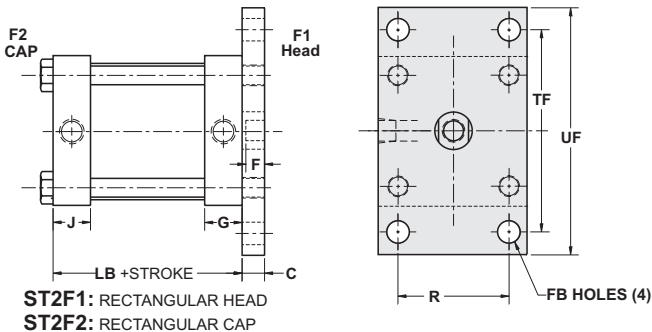

BORE	1 1/8	1 1/2	2	2 1/2	3 1/4	4	5
C	3/8	3/8	3/8	3/8	1/2	1/2	1/2
FB	5/16	5/16	3/8	3/8	7/16	7/16	9/16
G	5/8	5/8	5/8	5/8	31/32	31/32	31/32
J	5/8	5/8	5/8	5/8	31/32	31/32	31/32
LB	1 3/4	1 3/4	1 3/4	1 3/4	2 11/16	2 11/16	2 11/16
R	1.19	1.43	1.84	2.19	2.76	3.32	4.10
TF	2 3/8	2 3/4	3 3/8	3 7/8	4 11/16	5 7/16	6 5/8
UF	3	3 3/8	4 1/8	4 5/8	5 1/2	6 1/4	7 5/8

ST2F1: RECTANGULAR HEAD
ST2F2: RECTANGULAR CAP

ST2F1 & ST2F2 Rectangular mounts

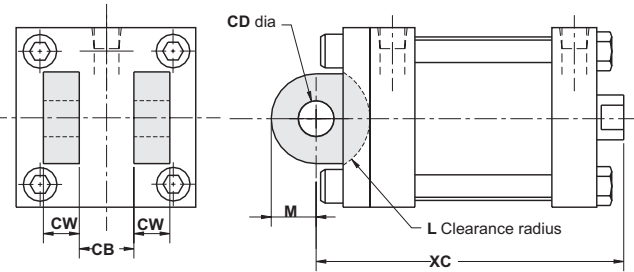

BORE	1 1/8	1 1/2	2	2 1/2	3 1/4	4	5
CB	3/4	3/4	3/4	3/4	1 1/4	1 1/4	1 1/4
CD	1/2	1/2	1/2	1/2	3/4	3/4	3/4
CW	3/8	3/8	1/2	1/2	3/4	3/4	3/4
L	3/4	3/4	3/4	3/4	1 1/4	1 1/4	1 1/4
M	5/8	5/8	5/8	5/8	7/8	7/8	7/8
XC	2 7/8	2 7/8	2 7/8	2 7/8	4 7/16	4 7/16	4 7/16

ST2P1 Detachable short clevis mount

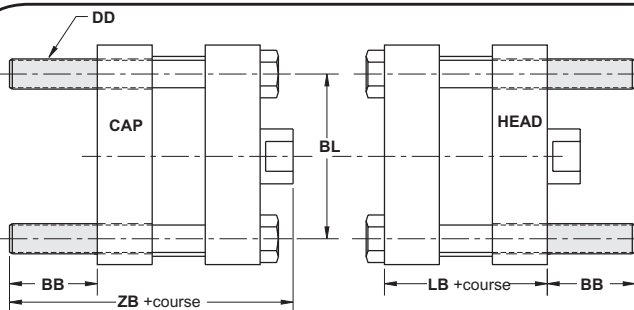

BORE	1 1/8	1 1/2	2	2 1/2	3 1/4	4	5
BB	7/8	7/8	1	1	1 1/4	1 1/4	1 1/2
BL	1.19	1.43	1.43	1.84	2.19	2.78	3.32
DD	#10-32	1/4-28	5/16-24	5/16-24	3/8-24	3/8-24	1/2-20
LB	1 3/4	1 3/4	1 3/4	1 3/4	1 3/4	2 11/16	2 11/16
ZB	2 1/8	2 1/8	2 1/8	2 1/8	3	3	3

ST2X1: Both tie rods extended
ST2X2: Cap end tie rods extended
ST2X3: Head end tie rods extended

ST2X Tie rods extended mounts

MOUNTING OPTIONS

BORE	1 1/8	1 1/2	2	2 1/2	3 1/4	4	5
SB	5/16	5/16	5/16	3/8	1/2	2 1/2	1/2
SH	1 1/16	1 1/4	1 1/2	1 13/16	2 3/8	2 3/4	3 1/4
SS	1 1/8	1 1/8	1 1/8	1 1/8	1 23/32	1 23/32	1 23/32
ST	1/4	1/4	1/4	1/4	1/2	1/2	1/2
TS	2 3/8	2 3/4	3 1/4	3 3/4	4 3/4	5 1/2	6 1/2
US	3 1/8	3 1/2	4	4 1/2	5 3/4	6 1/2	7 1/2
XL	3/4	3/4	3/4	3/4	1	1	1
XS	11/16	11/16	11/16	11/16	51/64	51/64	51/64

ST2S2 Side lug mount

BORE	1 1/8	1 1/2	2	2 1/2	3 1/4	4	5
AB	7/16	7/16	7/16	7/16	9/16	9/16	11/16
AH	1	1 3/16	1 7/16	1 5/8	1 15/16	2 1/4	2 3/4
AL	1	1	1	1	1 1/4	1 1/4	1 3/8
AO	1/2	1/2	1/2	1/2	1/2	1/2	5/8
AT	1/8	1/8	1/8	1/8	3/16	3/16	3/16
S	1 15/79	1 1/4	1 3/4	2 1/4	2 3/4	3 1/2	4 1/4
SA	3 3/4	3 3/4	3 3/4	3 3/4	5 3/16	5 3/16	5 7/16

ST2S1 Angle mount

(SUPPLIED WITH PIN & SNAP RING)

BORE	1 1/8	1 1/2	2	2 1/2	3 1/4	4	5
CB	3/4	3/4	3/4	3/4	1 1/4	1 1/4	1 1/4
CD	1/2	1/2	1/2	1/2	3/4	3/4	3/4
CW	3/8	3/8	1/2	1/2	3/4	3/4	3/4
FL	1 1/8	1 1/8	1 1/8	1 1/8	1 7/8	1 7/8	1 7/8
L	3/4	3/4	3/4	3/4	1 1/4	1 1/4	1 1/4
M	5/8	5/8	5/8	5/8	7/8	7/8	7/8
XD	3 1/4	3 1/4	3 1/4	3 1/4	5 1/16	5 1/16	5 1/16

ST2P2 Detachable clevis mount

(SUPPLIED WITH PIN & SNAP RING)

BORE	1 1/8	1 1/2	2	2 1/2	3 1/4	4	5
CB	3/4	3/4	3/4	3/4	1 1/4	1 1/4	1 1/4
CD	1/2	1/2	1/2	1/2	3/4	3/4	3/4
FL	1 1/8	1 1/8	1 1/8	1 1/8	1 7/8	1 7/8	1 7/8
L	3/4	3/4	3/4	3/4	1 1/4	1 1/4	1 1/4
M	5/8	5/8	5/8	5/8	7/8	7/8	7/8
XD	3 1/4	3 1/4	3 1/4	3 1/4	5 1/16	5 1/16	5 1/16

ST2P4 Detachable eye mount

MOUNTING OPTIONS & NFPA ACCESSORIES

STARCYL Standard Style 4 female thread

Option Style 2S (studded)

Option Style 2

Option Style 1 Large thread

Option Style 1F Full dia. thread

ROD DIA.	A	C	D	CC	FF	KK
1/2	5/8	3/8	3/8	7/16-20	1/2-20	3/8-24
5/8	3/4	3/8	1/2	1/2-20	5/8-18	7/16-20
1	1 1/8	1/2	7/8	7/8-14	1-14	3/4-16

Rod End Style

PART #	CB	CD	CE	CH	CW	ER	KK	L
RC-05	0.765	1/2	1 1/2	1	1/2	1/2	7/16-20	3/4
RC-07	1.265	3/4	2 3/8	1 1/4	5/8	3/4	3/4-16	1 1/4

OTHER SIZE ARE AVAILABLE, ASK YOUR DISTRIBUTOR OR FACTORY.
(RC-10 KK=1-14, RC-13 KK=1 1/4-12, RC-17 KK=1 1/2-12, ETC)

NFPA rod clevis

PART #	A	CA	CB	CD	ER	KK
RE-05	3/4	1 1/2	3/4	1/2	5/8	7/16-20
RE-07	1 1/8	2 1/16	1 1/4	3/4	7/8	3/4-16

OTHER SIZE ARE AVAILABLE, ASK YOUR DISTRIBUTOR OR FACTORY.
(RE-10 KK=1-14, RE-13 KK=1 1/4-12, RE-17 KK=1 1/2-12, ETC)

NFPA rod eye

PART #	CB	CD	CW	DD	E	FL	L	M	RE	USES ON BORE
CB-05	0.765	1/2	1/2	3/8-24	2 1/2	1 1/8	3/4	1/2	1 5/8	1 1/2 - 2 - 2 1/2"
CB-07	1.265	3/4	5/8	1/2-20	3 1/2	1 7/8	1 1/4	3/4	2 9/16	3 1/4 - 4 - 5"

NFPA Clevis Bracket

PART #	CB	CD	DD	E	FL	L	M	RE	USES ON BORE
CB-05	0.765	1/2	1/2	2 1/2	1 1/8	3/4	1/2	1 5/8	1 1/2 - 2 - 2 1/2"
CB-07	1.265	3/4	5/8	3 1/2	1 7/8	1 1/4	3/4	2 9/16	3 1/4 - 4 - 5"

NFPA Eye Bracket

HOW TO ORDER

EXAMPLE:

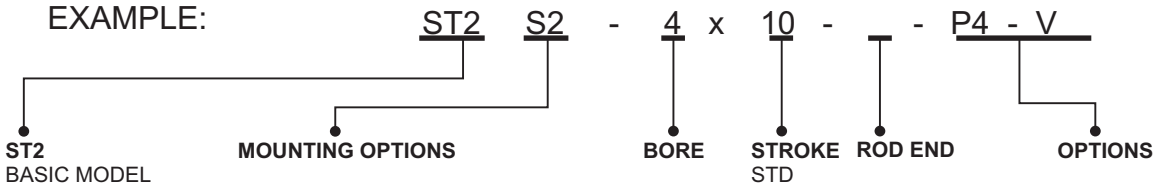

ST2D
DOUBLE ROD

- MOUNTING OPTIONS**
- F1 RECTANG. HEAD MOUNT
 - F2 RECTANG. CAP MOUNT
 - PI CLEVIS MOUNT
 - P2 DETACHABLE CLEVIS MOUNT
 - P4 EYE MOUNT
 - S1 ANGLE MOUNT
 - S2 SIDE LUG MOUNT
 - S4 BOTTOM TAP MOUNT
 - X1 BOTH TIE RODS EXTENDED
 - X2 CAP END TIE RODS EXTENDED
 - X3 HEAD END TIE RODS EXTENDED

- BORE**
- 1 1/2
 - 2
 - 2 1/2
 - 3 1/4
 - 4
 - 5
 - 10
 - 11
 - 12
- ask for other strokes

- STROKE**
- 1/2
 - 1
 - 1/2
 - 2
 - 2/12
 - 3
 - 3/12
 - 4

- ROD END**
- #1 MALE, large
 - #1F MALE, full dia.
 - #2 MALE, small
 - #2S MALE, studded
 - #4 FEMALE, STD

- OPTIONS**
- NC NUTS AT CAP END
 - PPx PORT POSITION (1,2,3,4)
 - REx ROD EXTENSION
 - UC U CUP SEALS
 - V SEALS MADE OF Viton™
 - W WIPER
 - M MAGNETIC PISTON
 - B BUMPER BOTH ENDS
 - BH BUMPER HEAD END
 - BC BUMPER CAP END
 - NR NON-ROTATING (for pick & place appl.)
 - BB BACK TO BACK
 - MP MULTI-POSITIONS
 - MS MULTI-STAGES
 - AS ADJUSTABLE STROKE

EXAMPLE ST2S2-4x10-PP4-V is a STAR2 series cylinder, 4" bore, 10" stroke, side lug mount, female rod thread, port position 4 with viton seals.

To order seal kits, add the prefix **ST2SK** to the bore diameter ex: **ST2SK-4**

Switch specifications

Switch part Number	LRS-004	LHS-31	LHS-32
Spec.	Reed Switch, MOV, LED	Electronic Sensor, LED, Sourcing	Electronic Sensor, LED, Sinking
Cable length	9ft PVC Cable		
Switching Voltage	5-120 VDC/VAC 50/60 Hz	6-24 VDC	6-24 VDC
Switching Current	0.5 Amp Max 0.005 Amp Min.	0.5 Amp Max.	0.5 Amp Max.
Switching power	10 Watts Max.	12 watts Max.	12 watts Max.
Switching Speed	0.5 mS operate 0.1 mS release	1.5µs operate 0.5µs release	1.5µs operate 0.5µs release
Voltage Drop	3.5 Volts	1.0 Volts	1.0 Volts
Temperature range	-20° to 80°C	-4° to 176°F	
Switch Function	SPST Normally Open	Normally open PNP output	Normally open NPN output
Shock	up to 30G (11msec.)	-	-
Vibration	up to 20G (10-55 Hz)	-	-

How To Order

Place Clamp code after switch Part Number.

Example: LRS-004-A

Reed switch for 1.5" Bore.

Bracket code Suffix

A = 1-1/8", 1 1/2", 2" & 2 1/2" bore

B = 3 1/4" & 4" bore

C = 5", 6" & 8" bore

NOTE : Add 1/4" to total length for 1-1/8 to 2 1/2" bore when using magnetic piston.

SELECTING BORE SIZE

The following formula may be used in the selection of the proper bore size:

- Extended (push) force in pounds =
(bore area in sq. in.) x (pressure in psi)

- Retract (pull) force in pounds =
(bore area in sq. in.) - (Rod area in sq. in.) x (pressure in psi)

Wiring Diagrams

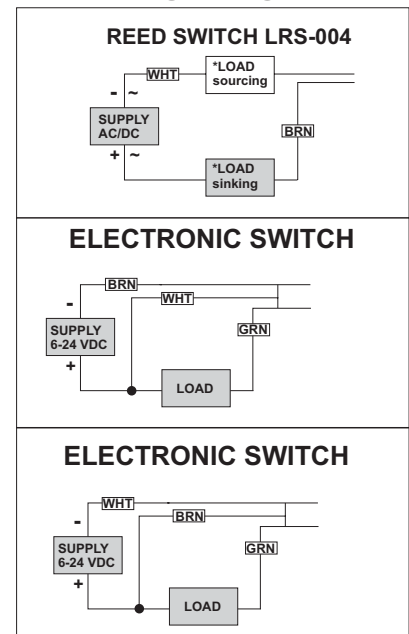

BORE (IN.)	AREA (SQ. IN.)	ROD SIZE (IN.)	ROD AREA (SQ. IN.)
1.125	0.994	0.500	0.196
1.5	1.767	0.625	0.307
2	2.142	0.625	0.307
2.5	4.909	0.625	0.307
3.25	8.296	1.000	0.785
4	12.566	1.000	0.785
5	19.635	1.000	0.785

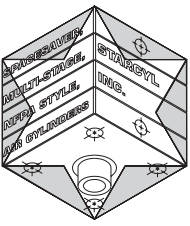

STARCYL

THE ONLY UPGRADABLE

MS: MULTI-STAGES AIR CYLINDER STAR2 SERIES NFPA STYLE MOUNT

SEE OUR BROCHURE FOR MOUNTING OPTIONS

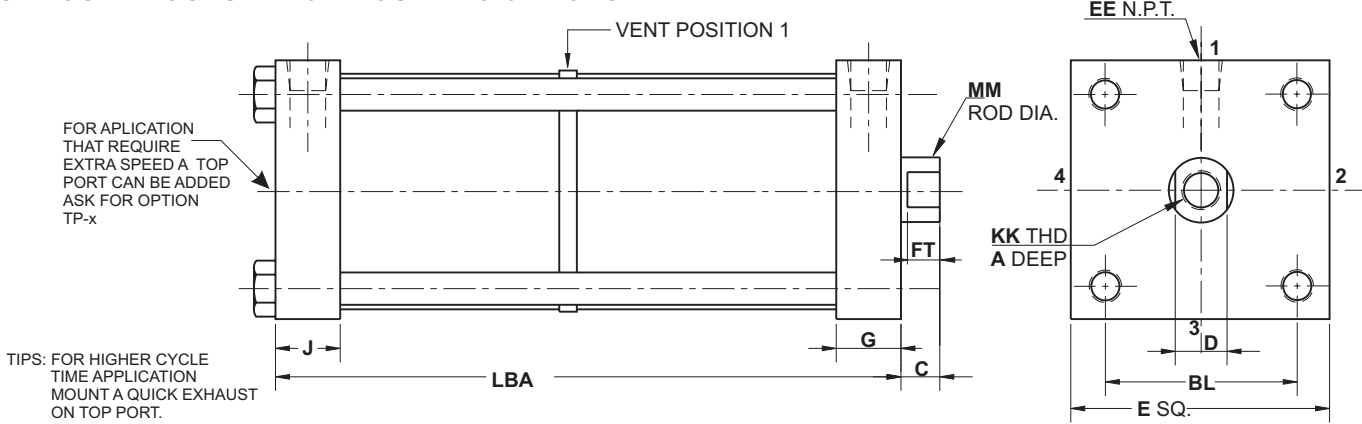

BORE	1.5	2	2.5	3.25	4	5	6	8
A	3/4	3/4	3/4	1 1/8	1 1/8	1 1/8	1 5/8	1 5/8
BL	1.43	1.84	2.19	2.78	3.32	4.12	4.88	6.44
C	3/8	3/8	3/8	1/2	1/2	1/2	5/8	5/8
D	1/2	1/2	1/2	7/8	7/8	7/8	1 3/16	1 3/16
E	2	2.5	3	3.75	4.5	5.5	6.5	8.5
EE	1/8	1/8	1/8	1/4	1/4	1/4	3/8	3/8
FT	5/16	5/16	5/16	7/16	7/16	7/16	1/2	1/2
G	5/8	5/8	5/8	31/32	31/32	31/32	1 7/16	1 7/16
J	5/8	5/8	5/8	31/32	31/32	31/32	31/32	1 7/16
KK	7/16-20	7/16-20	7/16-20	3/4-16	3/4-16	3/4-16	1-14	1-14
LBA	DIMENSION LBA EQUALS NUMBER OF STAGES TIMES STROKE PLUS YY							
MM	5/8	5/8	5/8	1	1	1	1 3/8	1 3/8

THE YY VALUE IS FOR STANDARD MULTI-STAGES EXTEND (MSE_x) OR RETRACT (MSR_x) MODELS. OPTIONAL MULTI-STAGES RETRACT-EXTEND (MSE_xR_x) REQUIRE ADDITIONAL LENGTH.

FORCES ARE GIVEN IN POUNDS AT 100 PSI

BORE	YY 2 STAGES	YY 3 STAGES	YY 4 STAGES	PUSH FORCE 2 STAGES	PUSH FORCE 3 STAGES	PUSH FORCE 4 STAGES	PUSH FORCE ADDER FOR ADD. STAGES
1 1/2	2 1/4	2 3/4	3 1/4	321	480	639	159
2	2 1/4	2 3/4	3 1/4	595	892	1188	296
2 1/2	2 1/4	2 3/4	3 1/4	949	1422	1895	473
3 1/4	3 3/8	4 1/16	4 3/4	1557	2331	3106	775
4	3 3/8	4 1/16	4 3/4	2411	3612	4814	1202
5	3 3/8	4 1/16	4 3/4	3825	5733	7642	1908
6	4 17/32	5 21/32	6 25/32	5467	8195	10923	2728
8	5 1/4	6 5/8	8	9865	14792	19719	4927

WE DO MORE THAN 4 STAGES ASK THE FACTORY FOR DIMENSIONS, DESIGN MAY CHANGE

- STANDARD STROKES: 1/2 - 1 - 1 1/2 - 2 - 2 1/2 - 3 - 4 - 5 - 6 inches
- OPTIONAL STROKES ANY OTHER STROKE THROUGH 12 inches

OTHER OPTIONS ARE AVAILABLE :

- PORTED BAFFLE
- ONE SIZE LARGER PORT
- TOP PORT (for higher cycle times)
- ADJUSTABLE EXTEND OR RETRACT STROKE
- HYDRAULIC CENTER-BALANCE

Available Mounting: Rectangular Head and cap Flange (MF1 MF2)
Tie rods Extended (MX1 MX2 MX3)
Angle Mount (MS1), Clevis Mount (MP1, MP2, MP4)

ADD ON MS-0397 FOR CATALOG STAR2-0397

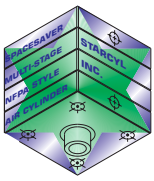

STARCYL

AIR CYLINDERS

OTHER PRODUCTS:

STARCYL AIR CYLINDERS
...To boldly go where no cylinder has gone before...

WWW.STARCYL.COM

- N.F.P.A. interchangeable
- Flush mount add
- 9 Bore sizes 1 1/2" through 10"
- Strokes - available to any practical length
- 18 standard Mounting Styles
- Check Seal Cushions
- 250 PSI AIR
- Two Year Warranty
- Economic design

STAR3 SERIES

STAR3 SERIES - N.F.P.A. INTERCHANGEABLE CYLINDERS
BORE SIZES 1 1/2" - 10"

STARCYL SPACESAVER AIR CYLINDERS

SINGLE OR MULTI-STAGE

THE ONLY CYLINDER UPGRADABLE!

**Not Enough Force
Don't Change The Design
Add A Stage!**

SL & RL LINE

MA-1095 UPGRADABLE SPACESAVER CYLINDERS

STARCYL SPACESAVER AIR CYLINDERS

ROUND LINE

- Buna N Quad ring rod and piston seal
- Hard anodized heavy wall aluminum alloy
- Heavy duty cap for hard conditions
- Rod bushing in oil-impregnated bronze
- All air cylinders are permanently lubricated
- Their design allows easy cleaning
- 250 psi, air or oil

RL-1095 ROUND LINE SPACESAVER CYLINDERS

PRESS-TOOL AIR PRESSES

1/2 TO 8 TONS

**ENTIRELY AIR OPERATED!
NO ELECTRICS, NO MECHANICS
NO HYDRAULICS.**

- PNEUMATIC CYLINDER WITH MULTI-STAGES GIVES INCREDIBLE FORCE AND SPEED
- T-SLOTTED RAM FOR BETTER ATTACHMENT OF DIES
- STANDARD T-SLOTTED PRESSURE PLATE
- WIDE OPENING IN BED (8X3)
- AIR PILOTED CONTROL VALVE
- HYDRAULIC CENTER BALANCE OR SPEED CONTROL (OPTION)
- FILTER REGULATOR LUBRICATOR (OPTION)
- ONE PIECE FRAME IN HIGH STRENGTH CAST IRON

TP & SP SERIES - AIR PRESSES 1/2 TO 8 TONS

FIND US ON THE INTERNET
WWW.STARCYL.COM
EMAIL : STARCYL@STARCYL.COM



STARCYL CYLINDER INC.

PH : 1-877-STARCYL (782-7295)
INT'L: 1-888-332-1711
FAX (425) 920-0504

IN CANADA: TEL: (450) 661-1212 FAX (450) 661-0094